

EXTREME[®] 300 SERIES GRILLE

MODELS CEPG324 (STRAIGHT), CEPG324B (BRICK)



MEASURE THE WIDTH AND HEIGHT OF THE OPENING

FACE OF WALL

6"	15"	15"	5.5"	11"	7"
7"	15"	15"			
8"	16"	16"			
9"	16"	16"			
10"	16"	16"			
11"	17"	17"			
12"	17"	17"			
13"	18"	18"			
14"	18"	18"			
15"	19"	19"			
16"	19"	19"			
HEIGHT	A	B	C	D	E

BETWEEN JAMBS

6"	17"	17"	5.5"	11"	7"
7"	17"	17"			
8"	17"	17"			
9"	17"	17"			
10"	17"	17"			
11"	17"	17"			
12"	17"	17"			
13"	18"	18"			
14"	18"	18"			
15"	19"	19"			
16"	19"	19"			
HEIGHT	A	B	C	D	E

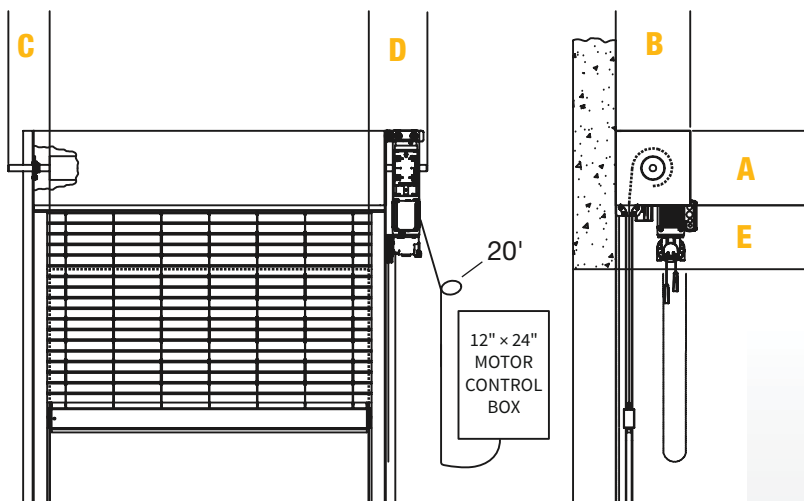

CURTAIN DESIGNS

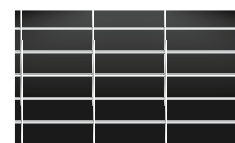

Straight

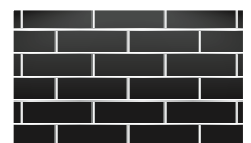

Brick

The dimensions featured on this sheet are provided as a guide.

GUIDE CONSTRUCTION OPTIONS

FACE OF WALL Z

Typically used with masonry wall construction, guides are mounted to the interior or exterior side of the wall.

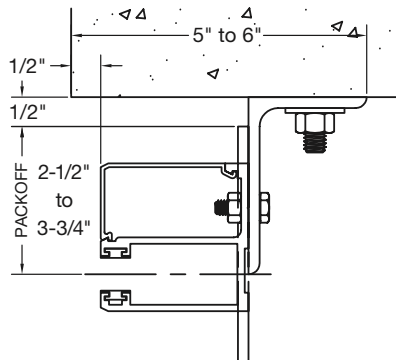

FACE OF WALL E

Typically used with steel jambs, guides are mounted to the interior or exterior side of the wall.

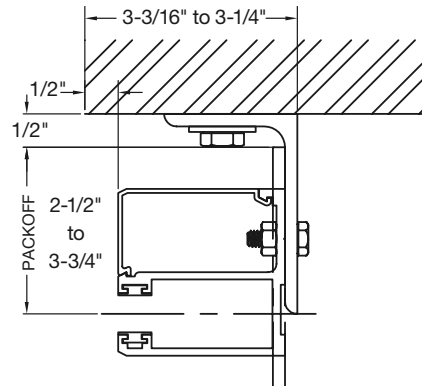

BELLMOUTH UHMW HIGH CYCLE

For quiet, efficient operation.

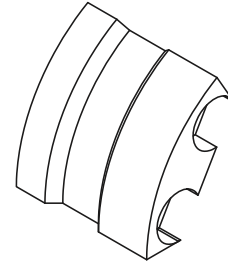

FACE OF WALL Z WITH 3x3 TUBES

Used when there is uneven or insufficient wall structure, guides are mounted to tubes attached to floor and overhead structure.

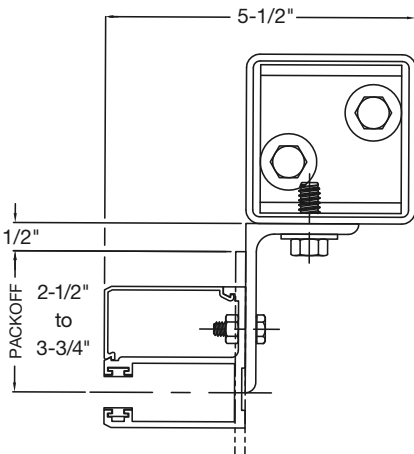

FACE OF WALL E WITH 3x3 TUBES

Used when there is uneven or insufficient wall structure, guides are mounted to tubes attached to floor and overhead structure.

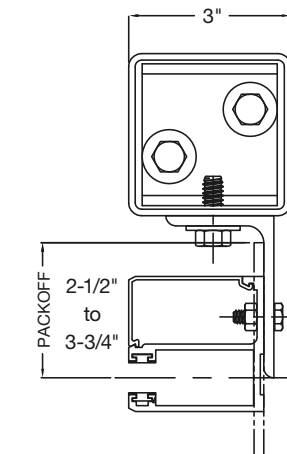

BETWEEN JAMBS WITH SQUARE TUBES (3x3 & 4x4 STEEL TUBES AVAILABLE)

Typically used if there's no wall support, trim piece required to provide clearance for operator.

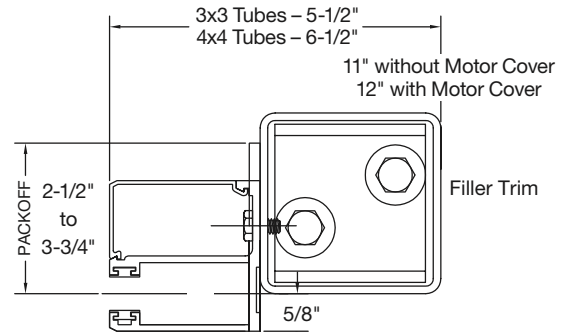

The dimensions featured on this sheet are provided as a guide.

CUSTOM-DESIGNED SOLUTIONS

Contact our experienced Architectural Design Support Team for help in customizing our products to fit your specific application at www.architectdoorhelp.com.



For more information on these and other Clopay products, visit clopaycommercial.com. Architects and specifiers, visit architectdoorhelp.com.

