

THERMISER MAX[®] – LOW U

MODEL CESD40



MEASURE THE WIDTH AND HEIGHT OF THE OPENING

DOOR SIZE AND AREA

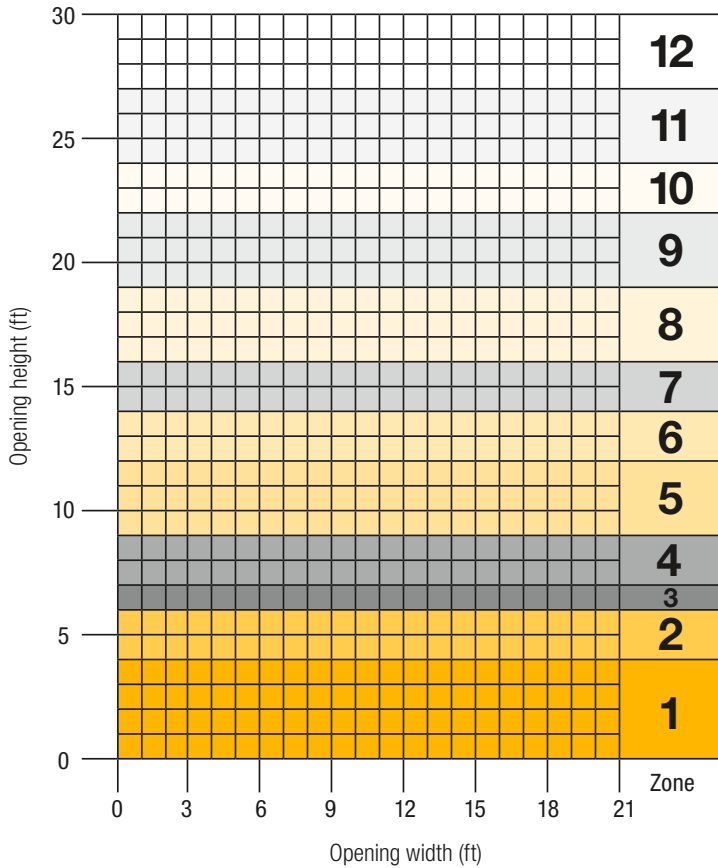

COMPONENT DIMENSIONS

Reference the zone number to view component dimensions for motorized doors.

Zone	A	B	C	D
1	15	17	7	7
2	16	18	7	7
3	17	19	7	7
4	18	20	7	7
5	19	21	7	7
6	20	22	7	7
7	21	23	7	7
8	22	24	7	7
9	23	25	7	7
10	24	26	7	7
11	25	27	7	7
12	26	28	7	7

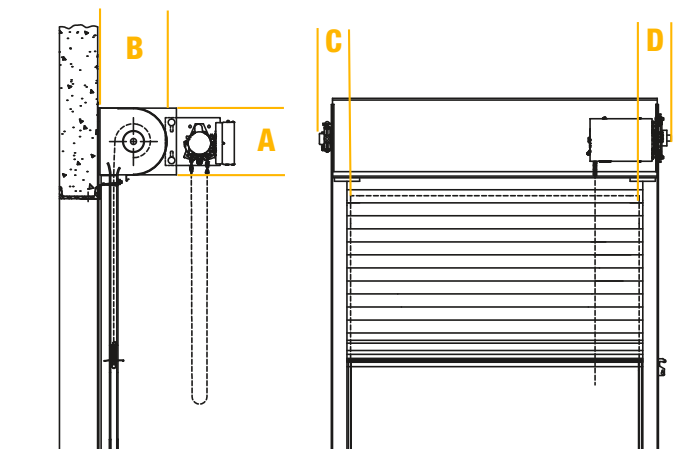

CURTAIN DESIGN

Insulated Slat

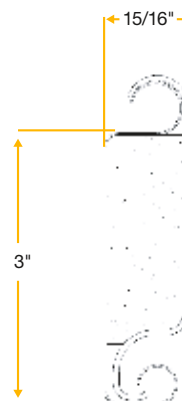

BOTTOM BAR

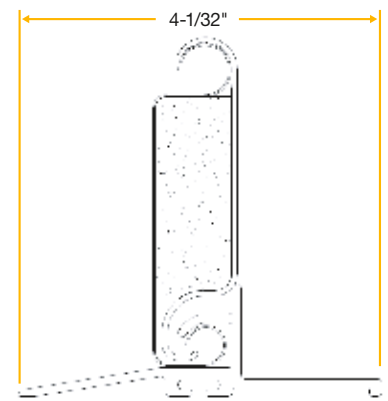

The dimensions featured on this sheet are provided as a guide.

INSULATED ROLLING DOOR

THERMISER MAX® – LOW U

GUIDE CONSTRUCTION OPTIONS

FACE OF WALL Z

Typically used with masonry wall construction, guides are mounted to the interior side of the wall.

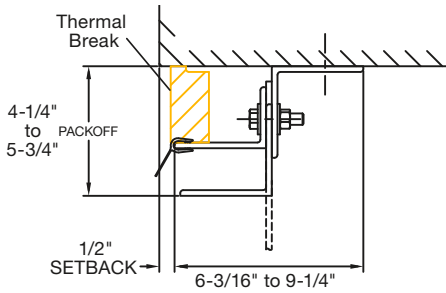

FACE OF WALL E

Typically used with steel jambs, guides are mounted to the interior side of the wall.

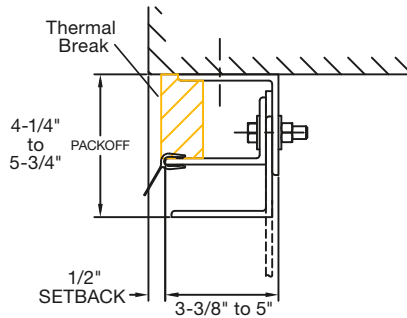

BETWEEN JAMBS

Used when side clearance is minimal, guides are mounted to the inside of the jamb.

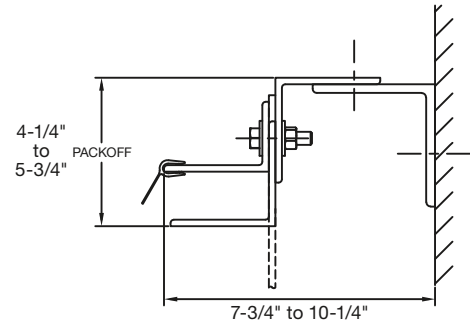

LINTEL SEAL BRUSH

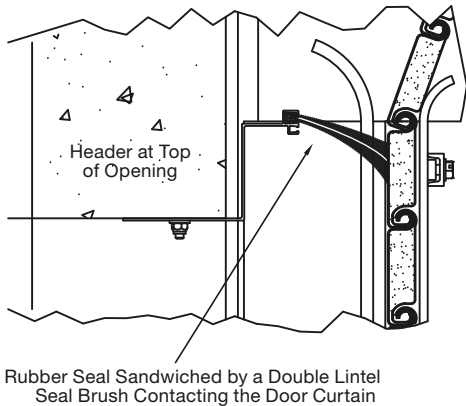

FOAM BLOCK

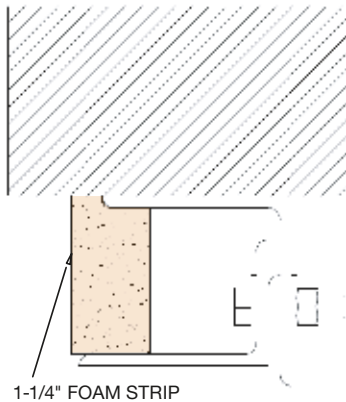

Sound Transmission Class (STC) rating is 27 for a full door when configured with 18GA steel front slats. Please contact the factory for details.

Air Infiltration value of less than .3 CFM/FT².

U-factor of Thermiser Max®– Low U is 0.532.*

Calculated using the ASHRAE Handbook of Fundamentals, tested per DASMA-105 by a third party.

**Options such as windows, pass doors, etc. may impact U-factor. Contact factory for details on specific configurations.*

The dimensions featured on this sheet are provided as a guide.

CUSTOM-DESIGNED SOLUTIONS

Contact our experienced Architectural Design Support Team for help in customizing our products to fit your specific application at www.architectdoorhelp.com.



For more information on these and other Clopay products, visit clopaycommercial.com. Architects and specifiers, visit architectdoorhelp.com.



©2024 Clopay Corporation. All rights reserved.

